

Max Load: 15Kgs

Part List:

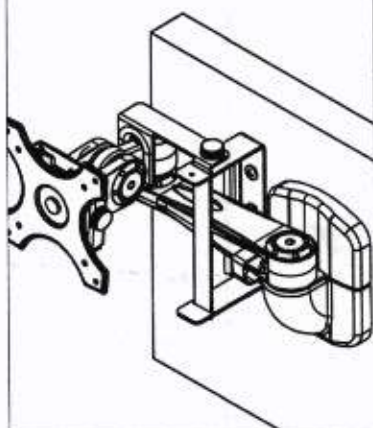

L. 1pc

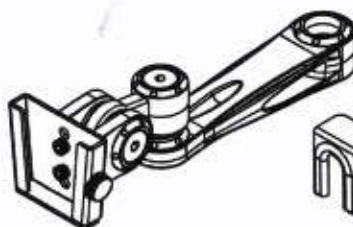

B. 1pc



A. 1pc

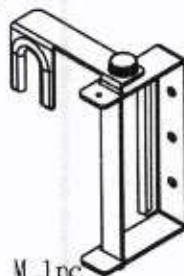

M. 1pc

1/4" x 2" C. 4pcs

M4x10 H. 4pcs

3/8" x 44 D. 1pc

E. 1pc

F. 1pc

3/8" G. 1pc

I. 1pc

J. 1pc

K. 1pc

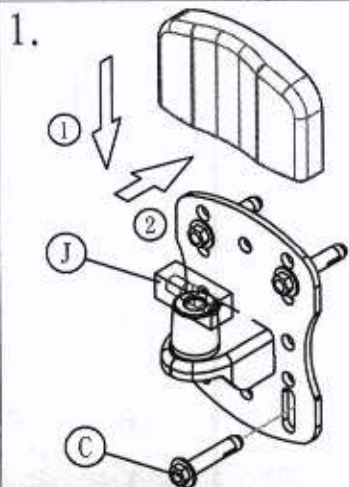

1.

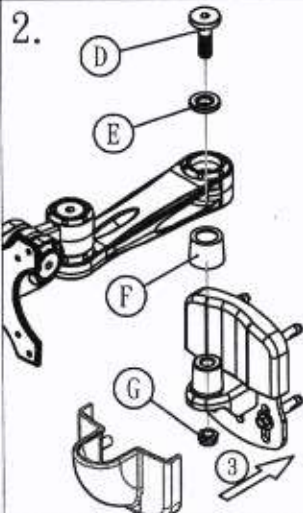

2.

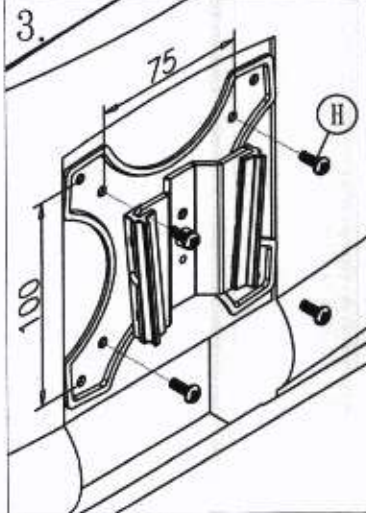

3.

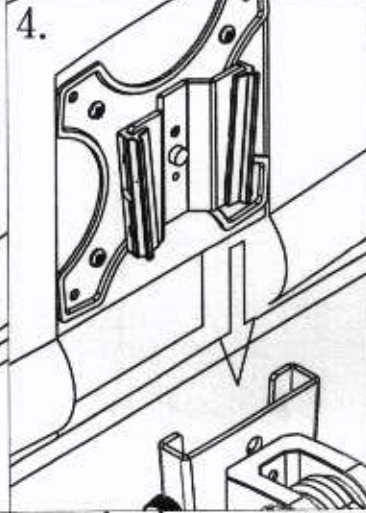

4.

Adjust torque... if necessary

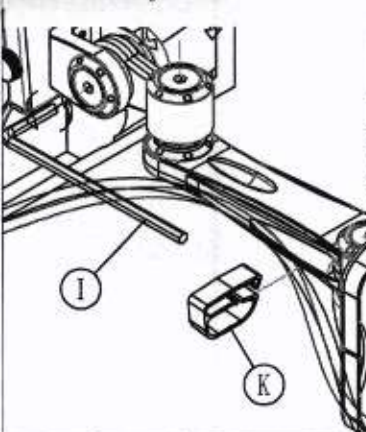

5. Place Locking bracket on the desired side (Left or Right) and assemble as pictured

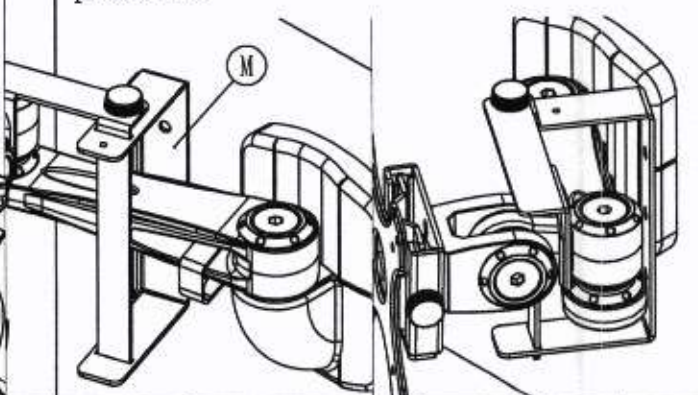

6. Place against the wall

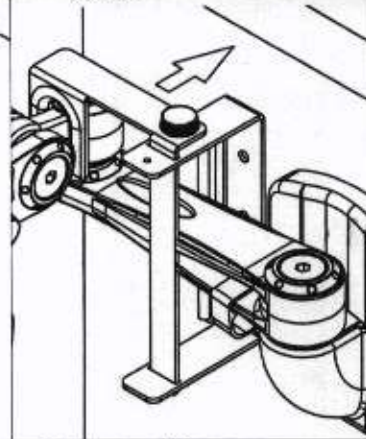

7. Mark the holes on the wall with a felt tip pen

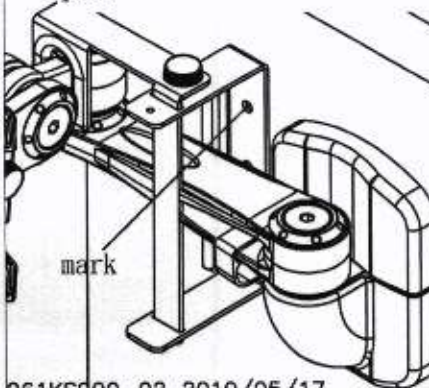

8. Mount and screw the locking bracket to the adjacent wall.

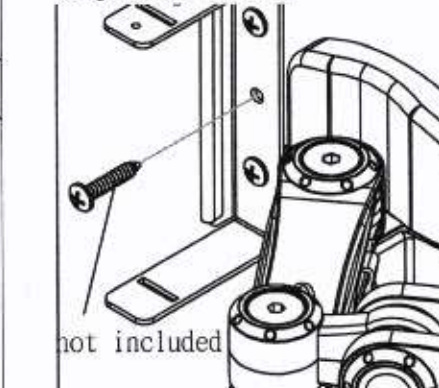

9. You have completed the job.

